

Q R G
M K 1 0 0 0
M i c r o K i o s k



symbol®



© 2002 SYMBOL TECHNOLOGIES, INC. All rights reserved.

Symbol reserves the right to make changes to any product to improve reliability, function, or design.

Symbol does not assume any product liability arising out of, or in connection with, the application or use of any product, circuit, or application described herein.

No license is granted, either expressly or by implication, estoppel, or otherwise under any patent right or patent, covering or relating to any combination, system, apparatus, machine, material, method, or process in which Symbol products might be used. An implied license exists only for equipment, circuits, and subsystems contained in Symbol products.

Symbol and the Symbol logo are registered trademarks of Symbol Technologies, Inc. Other product names mentioned in this manual may be trademarks or registered trademarks of their respective companies and are hereby acknowledged.

Symbol Technologies, Inc.
One Symbol Plaza
Holtsville, N.Y. 11742-1300
<http://www.symbol.com>

Patents

This product is covered by one or more of the following U.S. and foreign Patents:

U.S. Patent No. 4,593,186; 4,603,262; 4,607,156; 4,652,750; 4,673,805; 4,736,095; 4,758,717; 4,760,248; 4,806,742; 4,816,660; 4,845,350; 4,896,026; 4,897,532; 4,923,281; 4,933,538; 4,992,717; 5,015,833; 5,017,765; 5,021,641; 5,029,183; 5,047,617; 5,103,461; 5,113,445; 5,130,520; 5,140,144; 5,142,550; 5,149,950; 5,157,687; 5,168,148; 5,168,149; 5,180,904; 5,216,232; 5,229,591; 5,230,088; 5,235,167; 5,243,655; 5,247,162; 5,250,791; 5,250,792; 5,260,553; 5,262,627; 5,262,628; 5,266,787; 5,278,398; 5,280,162; 5,280,163; 5,280,164; 5,280,498; 5,304,786; 5,304,788; 5,306,900; 5,324,924; 5,337,361; 5,367,151; 5,373,148; 5,378,882; 5,396,053; 5,396,055; 5,399,846; 5,408,081; 5,410,139; 5,410,140; 5,412,198; 5,418,812; 5,420,411; 5,436,440; 5,444,231; 5,449,891; 5,449,893; 5,468,949; 5,471,042; 5,478,998; 5,479,000; 5,479,002; 5,479,441; 5,504,322; 5,519,577; 5,528,621; 5,532,469; 5,543,610; 5,545,889; 5,552,592; 5,557,093; 5,578,810; 5,581,070; 5,589,679; 5,589,680; 5,608,202; 5,612,531; 5,619,028; 5,627,359; 5,637,852; 5,664,229; 5,668,803; 5,675,139; 5,693,929; 5,698,835; 5,705,800; 5,714,746; 5,723,851; 5,734,152; 5,734,153; 5,742,043; 5,745,794; 5,754,587; 5,762,516; 5,763,863; 5,767,500; 5,789,728; 5,789,731; 5,808,287; 5,811,785; 5,811,787; 5,815,811; 5,821,519; 5,821,520; 5,823,812; 5,828,050; 5,848,064; 5,850,078; 5,861,615; 5,874,720; 5,875,415; 5,900,617; 5,902,989; 5,907,146; 5,912,450; 5,914,478; 5,917,173; 5,920,059; 5,923,025; 5,929,420; 5,945,658; 5,945,659; 5,946,194; 5,959,285; 6,002,918; 6,021,947; 6,029,894; 6,031,830; 6,036,098; 6,047,892; 6,050,491; 6,053,413; 6,056,200; 6,065,678; 6,067,297; 6,082,621; 6,084,528; 6,088,482; 6,092,725; 6,101,483; 6,102,293; 6,104,620; 6,114,712; 6,115,678; 6,119,944; 6,123,265; 6,131,814; 6,138,180; 6,142,379; 6,172,478; 6,176,428; 6,178,426; 6,186,400; 6,188,681; 6,209,788; 6,209,789; 6,216,951; 6,220,514; 6,243,447; 6,244,513; 6,247,647; 6,308,061; 6,250,551; 6,295,031; 6,308,061; 6,308,892; 6,321,990; 6,328,213; 6,330,244; 6,336,587; 6,340,114; 6,340,115; 6,340,119; 6,348,773; D305,885; D341,584; D344,501; D359,483; D362,453; D363,700; D363,918; D370,478; D383,124; D391,250; D405,077; D406,581; D414,171; D414,172; D418,500; D419,548; D423,468; D424,035; D430,158; D430,159; D431,562; D436,104.

Invention No. 55,358; 62,539; 69,060; 69,187 (Taiwan); No. 1,601,796; 1,907,875; 1,955,269 (Japan); European Patent 367,299; 414,281; 367,300; 367,298; UK 2,072,832; France 81/03938; Italy 1,138,713
rev. 03/02

Introduction

The MK1000 is a scanning system that allows retail shoppers to easily verify prices on bar coded merchandise and obtain up-to-the-minute information on in-store promotions -- while they shop.

The MK1000 does more than price verification. Its large easy-to-read display can be used as an electronic billboard for instant in-store merchandising and comes complete with the ability to display graphics and text messages to promote seasonal sales, in-store promotions, and upcoming events. The programmable function buttons can enhance in-store applications and allow for customer interaction.

About This Guide

This guide describes how to set up and use the MK1000. Specific topics covered include:

- *Parts of the MK1000* on page 2
- *Function Buttons* on page 3
- *Reset Button and Contrast Control Button* on page 3
- *Bar Code Scanning* on page 4
- *Scanning Modes* on page 4
- *Specular Reflection* on page 5
- *Mechanical Setup and Installation* on page 6
- *Mounting the MK1000 on a Wall* on page 7
- *Configuring for Host Communication* on page 8.

Parts of the MK1000

Front View

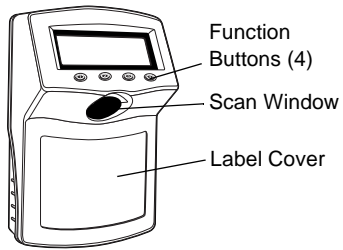

Back View

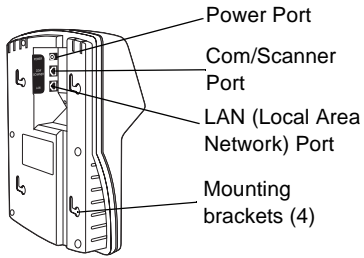

Lower Right Side

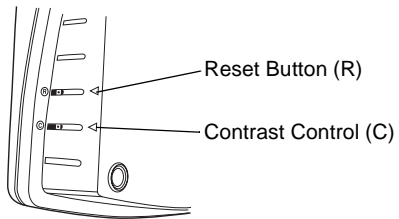

Function Buttons

The MK1000 has four programmable function buttons. These buttons can be programmed to allow the user to perform various tasks such as navigating through an application and making decisions when prompted.

Reset Button and Contrast Control Button

Reset Button

The Reset button can be used to reset the system. The Reset button is located on the lower right-hand side of the unit and marked with ®. Use a paper clip to push the switch.

Contrast Control Button



The display Contrast Control button is located below the Reset button and marked with ©. Use the tip of a small screwdriver to make contrast adjustments, if required.

Bar Code Scanning

The MK1000 automatically decodes a bar code presented in its field of view. It can decode all standard 1-dimensional bar codes plus PDF, micro-PDF, and composite bar codes.

Scanning Modes

The MK1000 operates in a number of different scan modes. Two of the most commonly used modes are described below.

Scan Mode	Description
Cyclone Omnidirectional 1D Scan Pattern (factory default)	This is a highly efficient scan pattern which decodes 1D and EAN/UCC reduced space symbologies in any orientation Note: While in this mode, the MK1000 does not decode 2D bar codes like PDF. 
Smart Raster Scan Pattern	Creates a single scan line which opens vertically for PDF-417 symbols using the Smart Raster feature. This feature autodetects the type of bar code being scanned and adjusts its pattern accordingly. This provides optimal performance on 1D, PDF-417, EAN/UCC, RSS and Composite Codes. 

Specular Reflection

When laser beams reflect *directly* back into the scanner from the bar code, they can “blind” the scanner and make decoding difficult. This phenomenon is called specular reflection.

To avoid this, scan the bar code so that the beam does not bounce *directly* back. But don't scan at too oblique an angle; the scanner needs to collect scattered reflections from the scan to make a successful decode. Practice quickly shows what tolerances to work within.

No Specular Reflection.

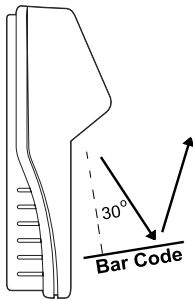

Decode can occur.

Tilt Bar Code At Slight Angle (Up to 30°)

Specular Reflection.

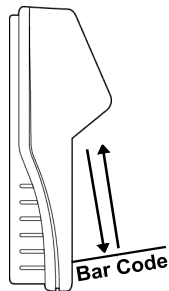

Reflected beam is within specular dead zone and prevents decode.

Mounting Template

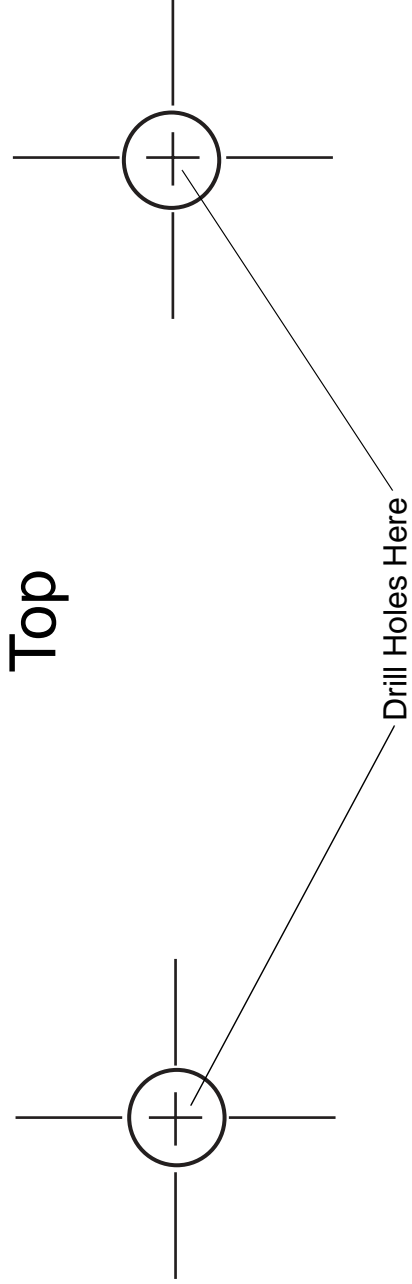

Note: There must be a clearance of at least 9/16 of an inch (14.3 mm) between the center of the right side mount holes and the nearest object.

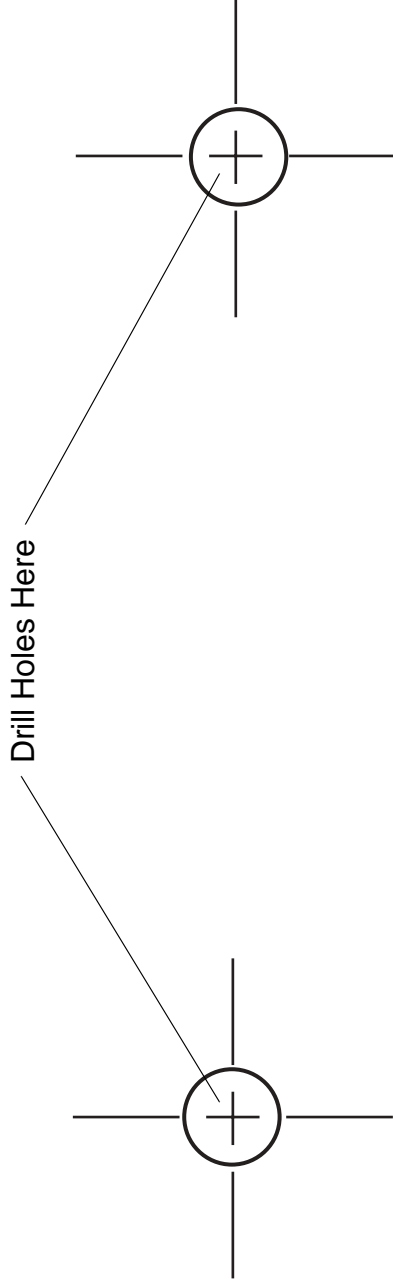

Mechanical Setup and Installation

The MK1000 can be connected to a host using one of the following four MK1000 communication interfaces.

See the *Product Reference Guide (p/n 72-53977-XX)* for cable pinouts.

Communication Interface	Description
Wireless Ethernet (2Mb or 11Mb RF) <ul style="list-style-type: none"> • Power via AC outlet • Power via Power-over-Ethernet 	The MK1000 can communicate with a host via a wireless (RF) Ethernet connection. When communicating in this manner the MK1000 can be powered either using the MK1000's power supply connected to an AC outlet, or by receiving Power-over-Ethernet via cable.
Wired Ethernet (10 Base-T cable) <ul style="list-style-type: none"> • Power via AC outlet • Power via Power-over-Ethernet 	The MK1000 can communicate with a host via a wired Ethernet connection (10Base-T cable). When communicating in this manner the MK1000 can be powered either using the MK1000's power supply connected to an AC outlet, or by receiving Power-over-Ethernet through the Ethernet cable.
Wired RS-485 (Serial cable)	The MK1000 can communicate with a host via a wired RS-485 Serial connection while receiving power via a power supply plugged into an AC outlet. For MK1000 devices installed where pre-existing PCK 9100 wiring exists, an RS-485 pin-out converter can be used. This pin-out converter maps the PCK 9100 signals into the required MK1000 pin-out and attaches to the existing PCK 9100 wiring, and then into the MK1000.
Wired RS-232 (Serial cable)	The MK1000 can communicate with a host via a Serial cable connected to the Com/Scanner port while receiving power via a power supply plugged into and AC outlet.

Mounting the MK1000 on a Wall

The MK1000 can be mounted on a wall, pole or counter top. Separately sold mounting accessories are listed below.

- Wall Mount Kit
- Pole Mount Kit
- Counter Top Stand

The MK1000 can also be mounted without the accessories listed above. To mount the MK1000 on a wall without using the wall mount kit, follow the instructions below.

1. Determine the MK1000 mounting location.
2. Using a pencil, mark the mounting screw location. Refer to the mounting template. The screws must be 5 inches (12.7 cm) apart, left to right: and, 6 inches (15.3 cm) apart, top to bottom.

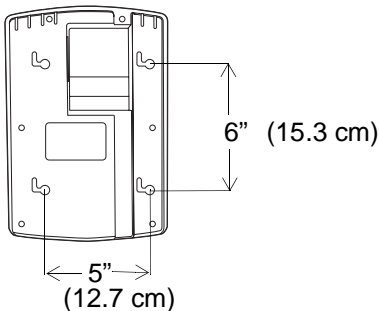

There must be a clearance of at least 9/16 of an inch (14.3mm) between the center of the right side mount holes and nearest object.

1. Install the mounting screws in the markings on the wall, leaving room for the mounting holes on the back of the MK1000 to slide onto. Ensure the screws are securely anchored to the wall.
2. Place the MK1000 on the wall, aligning the notches on the back of the unit with the mounting screws. Ensure all cables lie neatly in the channel provided on the back of the unit.
3. Slide the MK1000 to the left and down to secure in place.

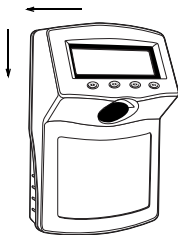

Configuring for Host Communication

The MK1000 can communicate with a host via PCK emulation. See the *Product Reference Guide (p/n 72-53977-xx)* for default Host Communication parameters, corresponding bar codes, and decode parameter bar codes.

Ergonomic Recommendations

Caution: In order to avoid or minimize the potential risk of ergonomic injury follow the recommendations below. Consult with your local Health & Safety Manager to ensure that you are adhering to your company's safety programs to prevent employee injury.

- Reduce or eliminate repetitive motion
- Maintain a natural position
- Reduce or eliminate excessive force
- Keep objects that are used frequently within easy reach
- Perform tasks at correct heights
- Reduce or eliminate vibration
- Reduce or eliminate direct pressure
- Provide adjustable workstations
- Provide adequate clearance
- Provide a suitable working environment
- Improve work procedures.

Regulatory Information

All Symbol devices are designed to be compliant with rules and regulations in locations they are sold and will be labeled as required.

Any changes or modifications to Symbol Technologies equipment, not expressly approved by Symbol Technologies, could void the user's authority to operate the equipment.



FCC RF Exposure Guidelines

To comply with FCC RF exposure requirements, antennas that are mounted externally at remote locations or operating near users at stand-alone desktop of similar configurations must operate with a minimum separation distance of 20 cm from all

persons.

Radio Frequency Interference Requirements



This equipment has been tested and found to comply with the limits for a Class B digital device, pursuant to Part 15 of the FCC rules. These limits are designed to provide reasonable protection against harmful interference in a residential installation. This equipment generates, uses, and can radiate radio frequency energy and, if not installed and used in accordance with the instructions, may cause harmful

interference to radio communications. However there is no guarantee that interference will not occur in a particular installation. If the equipment does cause harmful interference to radio or television reception, which can be determined by turning the equipment off and on, the user is encouraged to try to correct the interference by one or more of the following measures:

- Re-orient or relocate the receiving antenna
- Increase the separation between the equipment and receiver
- Connect the equipment into an outlet on a circuit different from that to which the receiver is connected
- Consult the dealer or an experienced radio/TV technician for help.

Radio Frequency Interference Requirements - Canada

This Class B digital apparatus complies with Canadian ICES-003.

Cet appareil numérique de la classe B est conforme à la norme NMB-003 du Canada.

This device complies with RSS 210 of Industry & Science Canada. Operation is subject to the following two conditions: (1) this device may not cause harmful interference and (2) this device must accept any interference received, including interference that may cause undesired operation.

Laser Devices



Symbol products using lasers comply with US 21CFR1040.10, and IEC825-1:1993, EN60825-1:1994+A11:1996. The laser classification is marked on one of the labels on the product.

Class 1 Laser devices are not considered to be hazardous when used for their intended purpose. The following statement is required to comply with US and international regulations:

Caution: Use of controls, adjustments or performance of procedures other than those specified herein may result in hazardous laser light exposure.

Class 2 laser scanners use a low power, visible light diode. As with any very bright light source, such as the sun, the user should avoid staring directly into the light beam. Momentary exposure to a Class 2 laser is not known to be harmful.



Marking and European Economic Area (EEA)

RLAN's (2.4GHz) for use through the EEA have the following restrictions:

- Maximum radiated transmit power of 100 mW EIRP in the frequency range 2.400 - 2.4835 GHz
- France, equipment is restricted to 2.4465 - 2.4835 GHz frequency range
- Belgium outside usage, the equipment is restricted to 2.460 - 2.4835 GHz frequency range
- Italy requires a user license for outside usage.

Other Countries

- Mexico - Restrict Frequency Range of: 2.450 - 2.4835 GHz.

Statement of Compliance for radio devices

Symbol Technologies, Inc., hereby, declares that this device is in compliance with the essential requirements and other relevant provisions of Directive 1999/5/EC. A Declaration of Conformity may be obtained from <http://www2.symbol.com/doc/>

Power Supply

Note: Use only a Symbol-approved power supply output rated 12-36 Vdc or 12-24-vac and minimum 16va. The power supply is certified to EN60950 with SELV outputs.

Hinweis: Benutzen Sie nur eine Symbol Technologies genehmigt Stromversorgung) in den Ausgabe: 12-36 Vdc or 12-24-vac und minimum 16va. Die Stromversorgung ist bescheinigt nach EN60950 mit SELV Ausgaben.

Q u i c k R e f e r e n c e

Scanner Labeling



M K 1 0 0 0

M i c r o K i o s k

In accordance with Clause 5, IEC 825 and EN60825, the following information is provided to the user:



ENGLISH

CLASS 1 CLASS 1 LASER PRODUCT
 CLASS 2 LASER LIGHT
 DO NOT STARE INTO BEAM
 CLASS 2 LASER PRODUCT

HEBREW

רמה 1 מוצר לייזר רמה 1
 רמה 2 אור לייזר
 אין להביט אל תוך הזרם
 מוצר לייזר רמה 2

DANISH / DANSK

KLASSE 1 KLASSE 1 LASERPRODUKT
 KLASSE 2 LASERLYF
 SE IKKE IND I STRÅLEN
 KLASSE 2 LASERPRODUKT

ITALIAN / ITALIANO

CLASSE 1 PRODOTTO AL LASER DI CLASSE 1
 CLASSE 2 LUCE LASER
 NON FISSARE IL RAGGIOPRODOTTO
 AL LASER DI CLASSE 2

DUTCH / NEDERLANDS

KLASSE 1 KLASSE-1 LASERPRODUKT
 KLASSE 2 LASERLICHT
 NIET IN STRAAL STAREN
 KLASSE-2 LASERPRODUKT

NORWEGIAN / NORSK

KLASSE 1 LASERPRODUKT, KLASSE 1
 KLASSE 2 LASERLYS IKKE STIRR INN I LYSSTRÅLEN
 LASERPRODUKT, KLASSE 2

FINNISH / SUOMI

LUOKKA 1 LUOKKA 1 LASERTUOTE
 LUOKKA 2 LASERVALO
 ÄLÄ TUIJOTA SÄDETTÄ
 LUOKKA 2 LASERTUOTE

PORTUGUESE / PORTUGUÊS

CLASSE 1 PRODUTO LASER DA CLASSE 1
 CLASSE 2 LUZ DE LASER NÃO FIXAR O RAIOS LUMINOSOS
 PRODUTO LASER DA CLASSE 2

FRENCH / FRANÇAIS

CLASSE 1 PRODUIT LASER DE CLASSE 1
 CLASSE 2 LUMIÈRE LASER
 NE PAS REGARDER LE RAYON FIXEMENT
 PRODUIT LASER DE CLASSE 2

SPANISH / ESPAÑOL

CLASE 1 PRODUCTO LASER DE LA CLASE 1
 CLASE 2 LUZ LASER
 NO MIRE FIJAMENTE EL HAZ
 PRODUCTO LASER DE LA CLASE 2

GERMAN / DEUTSCH

KLASSE 1 LASERPRODUKT DER KLASSE 1
 KLASSE 2 LASERSTRAHLEN
 NICHT DIREKT IN DEN LASERSTRAHL SCHAUEN
 LASERPRODUKT DER KLASSE 2

SWEDISH / SVENSKA

KLASS 1 LASERPRODUKT KLASS 1
 KLASS 2 LASERLJUS STIRRA INTE MOT STRÅLEN
 LASERPRODUKT KLASS 2

Warranty

Symbol Technologies, Inc. ("Symbol") manufactures its hardware products in accordance with industry-standard practices. Symbol warrants that for a period of twelve (12) months from date of shipment, products will be free from defects in materials and workmanship.

This warranty is provided to the original owner only and is not transferable to any third party. It shall not apply to any product (i) which has been repaired or altered unless done or approved by Symbol, (ii) which has not been maintained in accordance with any operating or handling instructions supplied by Symbol, (iii) which has been subjected to unusual physical or electrical stress, misuse, abuse, power shortage, negligence or accident or (iv) which has been used other than in accordance with the product operating and handling instructions. Preventive maintenance is the responsibility of customer and is not covered under this warranty.

Wear items and accessories having a Symbol serial number will carry a 90-day limited warranty. Non-serialized items will carry a 30-day limited warranty.

Warranty Coverage and Procedure

During the warranty period, Symbol will repair or replace defective products returned to Symbol's manufacturing plant in the US. For warranty service in North America, call the Symbol Support Center at 1-800-653-5350. International customers should contact the local Symbol office or support center. If warranty service is required, Symbol will issue a Return Material Authorization Number. Products must be shipped in the original or comparable packaging, shipping and insurance charges prepaid. Symbol will ship the repaired or replacement product freight and insurance prepaid in North America. Shipments from the US or other locations will be made F.O.B. Symbol's manufacturing plant.

Symbol will use new or refurbished parts at its discretion and will own all parts removed from repaired products. Customer will pay for the replacement product in case it does not return the replaced product to Symbol within 3 days of receipt of the replacement product. The process for return and customer's charges will be in accordance with Symbol's Exchange Policy in effect at the time of the exchange.

Customer accepts full responsibility for its software and data including the appropriate backup thereof.

Repair or replacement of a product during warranty will not extend the original warranty term.

Symbol's Customer Service organization offers an array of service plans, such as on-site, depot, or phone support, that can be implemented to meet customer's special operational requirements and are available at a substantial discount during warranty period.

General

Except for the warranties stated above, Symbol disclaims all warranties, express or implied, on products furnished hereunder, including without limitation implied warranties of merchantability and fitness for a particular purpose. The stated express warranties are in lieu of all obligations or liabilities on part of Symbol for damages, including without limitation, special, indirect, or consequential damages arising out of or in connection with the use or performance of the product.

Service Information

Before you use the unit, it must be configured to operate in your facility's network and run your applications.

If you have a problem running your unit or using your equipment, contact your facility's Technical or Systems Support. If there is a problem with the equipment, they will contact the Symbol Support Center:

United States ¹	1-800-653-5350 1-631-738-2400	Canada	905-629-7226
United Kingdom	0800 328 2424	Asia/Pacific	337-6588
Australia	1-800-672-906	Austria/Österreich	1-505-5794-0
Denmark/Danmark	7020-1718	Finland/Suomi	9 5407 580
France	01-40-96-52-21	Germany/Deutschland	6074-49020
Italy/Italia	2-484441	Mexico/México	5-520-1835
Netherlands/Nederland	315-271700	Norway/Norge	+47 2232 4375
South Africa	11-8095311	Spain/España	+913244000
Sweden/Sverige	84452900		
Latin America Sales Support	1-800-347-0178 Inside US +1-561-483-1275 Outside US		
Europe/Mid-East Distributor Operations	Contact local distributor or call +44 118 945 7360		

¹Customer support is available 24 hours a day, 7 days a week.

For the latest version of this guide go to:<http://www.symbol.com/manuals>.



72-52968-02
Revision A — March 2002